

**Modular Cooking Range Line
 thermaline 90 - Full Module
 Freestanding Electric Fry Top with Mixed
 Plate, 1 Side, H=800**

ITEM # _____

MODEL # _____

NAME # _____

SIS # _____

AIA # _____



589568 (MCHFFAHDAO) Electric fry top with smooth and ribbed chrome plate, one-side operated

Short Form Specification

Item No. _____

Unit constructed according to DIN 18860_2 with 20 mm drop nose top and 70 mm recessed plinth. Internal frame for heavy duty sturdiness in 2 mm and 3 mm in 1.4301 (AISI 304). 2 mm top in 1.4301 (AISI 304). Flat surface construction, easily cleanable. THERMODUL connection system enables seamless worktop when units are connected and avoids soil penetrating. Chromium-plated mild steel cooking surface with non-stick finishing for optimal grilling. Electrical control via thermocouples for precise temperature control and safety thermostat. Large drain hole allows draining of cooking juices into a large collector. Overheat protection switches off the supply in case of overheating. Metal knobs with embedded hygienic silicon "soft" grip enable easier handling and cleaning. IPX5 water resistant certification. Configuration: Freestanding, One-side operated.

Main Features

- Choice of one or two heating zones. An indicator lamp shows operating state of each zone.
- Large drain hole on cooking surface permits the draining of residual cooking juices into a large collector placed under the cooking surface.
- Overheat protection: a temperature sensor switches off the supply in case of overheating.
- Stainless steel high splash guards on the rear and sides of cooking surface.
- Units have separate controls for each half module of the cooking surface.
- All major components may be easily accessed from the front.
- THERMODUL connection system creates a seamless work top when units are connected to each other thus avoiding soil penetrating vital components and facilitating the removal of units in case of replacement or service.
- Metal knobs with embedded hygienic "soft-touch" grip for easier handling and cleaning. The special design of the controls prevents infiltration of liquids or soil into vital components.
- Large visible digital display manufactured in tempered glass to resist heat and chemicals, showing temperatures or power settings. The display also shows on/off status of the appliance and on/off status of the heating elements.
- Powerblock heating system for optimal temperature distribution.

Construction

- 2 mm top in 1.4301 (AISI 304).
- Unit constructed according to DIN 18860_2 with 20 mm drop nose top and 70 mm recessed plinth.
- Flat surface construction with minimal hidden areas to easily clean all surfaces
- Cooking surface in chromium-plated mild steel with non-stick finishing for optimum grilling results.
- IPX5 water resistance certification.
- Cooking surface 2/3 smooth and 1/3 ribbed.
- Internal frame for heavy duty sturdiness in stainless steel.

Sustainability

- Standby function for energy saving and fast recovery of maximum power.



APPROVAL: _____

Optional Accessories

- Connecting rail kit, 900mm PNC 912502
- Stainless steel side panel (12mm), 900x800mm, freestanding PNC 912511
- Portioning shelf, 800mm width PNC 912526
- Portioning shelf, 800mm width PNC 912556
- Folding shelf, 300x900mm PNC 912581
- Folding shelf, 400x900mm PNC 912582
- Fixed side shelf, 200x900mm PNC 912589
- Fixed side shelf, 300x900mm PNC 912590
- Fixed side shelf, 400x900mm PNC 912591
- Stainless steel front kicking strip, 800mm width PNC 912598
- Stainless steel side kicking strips left and right, freestanding, 900mm width PNC 912621
- Stainless steel side kicking strips left and right, back-to-back, 1800mm width PNC 912627
- Stainless steel plinth, freestanding, 800mm width PNC 912920
- Connecting rail kit, right PNC 912975
- Connecting rail kit, left PNC 912976
- Endrail kit, flush-fitting, left PNC 913111
- Endrail kit, flush-fitting, right PNC 913112
- Scraper for smooth plates PNC 913119
- Scraper for ribbed plates PNC 913120
- Endrail kit (12mm) for thermaline 90 units, left PNC 913202
- Endrail kit (12mm) for thermaline 90 units, right PNC 913203
- Stainless steel side panel, left, H=800, flush PNC 913224
- Stainless steel side panel, left, H=800, flush PNC 913225
- T-connection rail for back to back installations without backsplash PNC 913227
- - NOT TRANSLATED - PNC 913232
- - NOT TRANSLATED - PNC 913234
- - NOT TRANSLATED - PNC 913246
- - NOT TRANSLATED - PNC 913251
- - NOT TRANSLATED - PNC 913252
- - NOT TRANSLATED - PNC 913255
- - NOT TRANSLATED - PNC 913256
- - NOT TRANSLATED - PNC 913259
- - NOT TRANSLATED - PNC 913277
- - NOT TRANSLATED - PNC 913278
- - NOT TRANSLATED - PNC 913281
- - NOT TRANSLATED - PNC 913665
- STAINLESS STEEL DIVIDING PANEL 900X800MM LEFT/RIGHT PNC 913673
- ELECTRIC MAINSWITCH 25A 4mm² NM FOR MODULAR H800 ELECTRIC UNITS (FACTORY FITTED) PNC 913676
- STAINLESS STEEL SIDE COVER PANEL, FLUSH 900X800MM LEFT/RIGHT PNC 913689

Recommended Detergents

- *NOT TRANSLATED* PNC 0S2292

Front

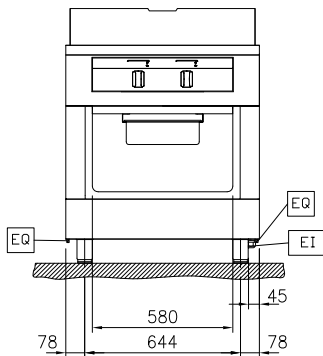

Side

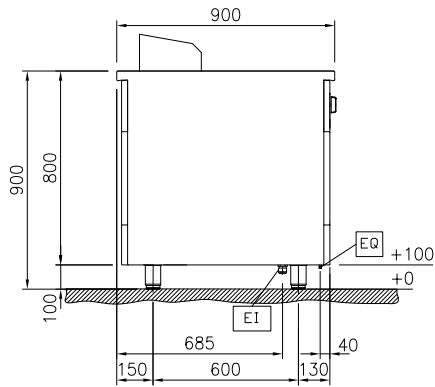

EI = Electrical inlet (power)
 EQ = Equipotential screw

Top

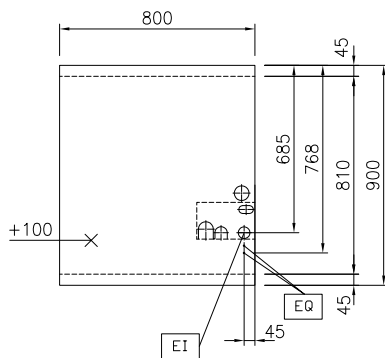
Electric

Supply voltage: 400 V/3N ph/50/60 Hz
 Total Watts: 15.3 kW

Key Information:

Cooking Surface Depth: 615 mm
 Cooking Surface Width: 700 mm
 Working Temperature MIN: 80 °C
 Working Temperature MAX: 280 °C
 External dimensions, Width: 800 mm
 External dimensions, Depth: 900 mm
 External dimensions, Height: 800 mm
 Storage Cavity Dimensions (width): 580 mm
 Storage Cavity Dimensions (height): 330 mm
 Storage Cavity Dimensions (depth): 740 mm
 Net weight: 150 kg
 Configuration: On Base; One-Side Operated
 Cooking surface type: half ribbed/ half smooth
 Cooking surface - material: Chromium Plated mild steel mirror

Sustainability

Current consumption: 22.1 Amps